

COMPRESSED AIR TREATMENT



CLEAN COMPRESSED AIR

Economical and safe treatment of compressed air

To produce one cubic metre of compressed air with an overpressure of 10 bar, a compressor has to suck in eleven cubic metres of ambient air. Together with this air, it also sucks in all the impurities it contains, just like a large vacuum cleaner: dust, fumes, oil vapour, chemicals, etc. Added to this is the natural air humidity.

Despite high-quality intake filters, all these components of the intake air are found in the compressed air. The substances that were distributed over eleven cubic metres of ambient air before compression are now concentrated in a single cubic metre of compressed air. To ensure trouble-free operation, dirt, water and oil must therefore be separated from the compressed air.

Concentration of pollutants

in atmospheric air

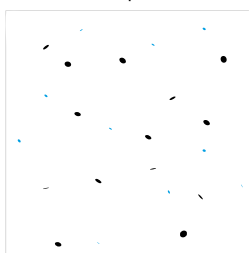

at 10 bar overpressure

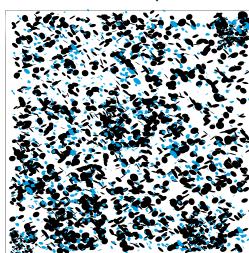

Humidity

Compressed air contains moisture depending on the ambient conditions. Depending on the application, this moisture must be extracted from the compressed air. There are the following possibilities:

- Cyclone separator: removes free water droplets from the compressed air.

- Refrigeration dryer: possible dew point up to max. +3 °C
- Adsorption dryer: possible dew point down to -70 °C.

Which drying is required in individual cases depends on the consumers operated.

Symptoms of incorrectly designed drying are moisture in the compressed air network, icing in winter or increased component wear due to corrosion.

To drain moisture from the compressed air system and dispose of it properly, it is recommended to use:

- Condensate drain
- Oil- Water separators

Solid impurities/oil

In addition to moisture, the compressed air is also contaminated with particles and oil. To remove these components, it is recommended to use filters such as:

- Coarse filter
- Microfilter
- Submicrofilter
- Activated carbon filter
- Activated carbon adsorber

By combining different preparation methods, the purity classes prescribed or recommended for the respective applications can be achieved.

Compressed air storage

Compressed air tanks are used to store the generated compressed air. The required size is determined by calculation.

Compressed air quality classes according to ISO 8573-1:2010

ISO 8573-1:2010	Solid impurities			Humidity (vaporous)		Total oil content (liquid & gaseous)	
Class	0,1µ < d ≤ 0,5µ	0,5µ < d ≤ 1,0µ	1,0µ < d ≤ 5,0µ	Pressure dew point			
0	better than Class 1 and to be agreed separately						
1	≤ 20.000	≤ 400	≤ 10	≤ -70°C		≤ 0,01 mg/m ³	
2	≤ 400.000	≤ 6.000	≤ 100	≤ -40°C		≤ 0,1 mg/m ³	
3	—	≤ 90.000	≤ 1.000	≤ -20°C		≤ 1 mg/m ³	
4	—	—	≤ 10.000	≤ +3°C		≤ 5 mg/m ³	
5	—	—	≤ 1000.000	≤ +7°C		—	
6	Mass concentration C _p (mg/m ³)		0 < C _p ≤ 5	≤ +10°C		—	
7			5 < C _p ≤ 10	Residual humidity	cw ≤ 0,5		—
8	C _p < 10		cw g/m ³		0,5 < cw ≤ 5		—
9	—	—		—	5 < cw ≤ 10		—
X	—	—	—	—	cw ≤ 10		> 5 mg/m ³
Maximum number of particles per m ³ of the given size in µm measured according to ISO 8573-4 Reference conditions: 1 bar absolute, 20°C, 0% r. h.			Maximum pressure dew point measured according to ISO 8573-3 at operating pressure. Reference conditions for residual humidity: 1 bar absolute, 20°C, 0% r. h.			Maximum total oil content measured according to ISO 8573-2 and ISO 8573-5. Reference conditions: 1 bar absolute, 20°C, 0% r. h.	

Compressed air treatment with refrigeration dryer

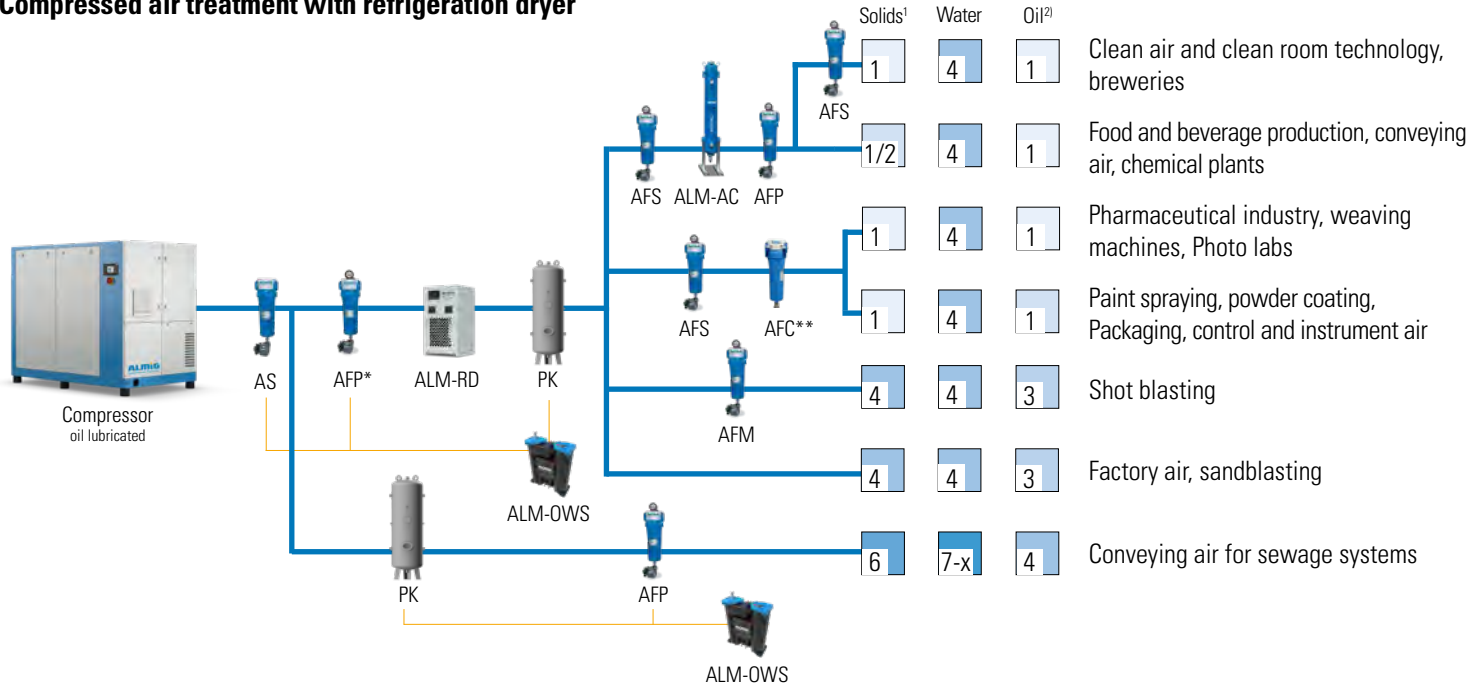

Compressed air treatment with adsorption dryer

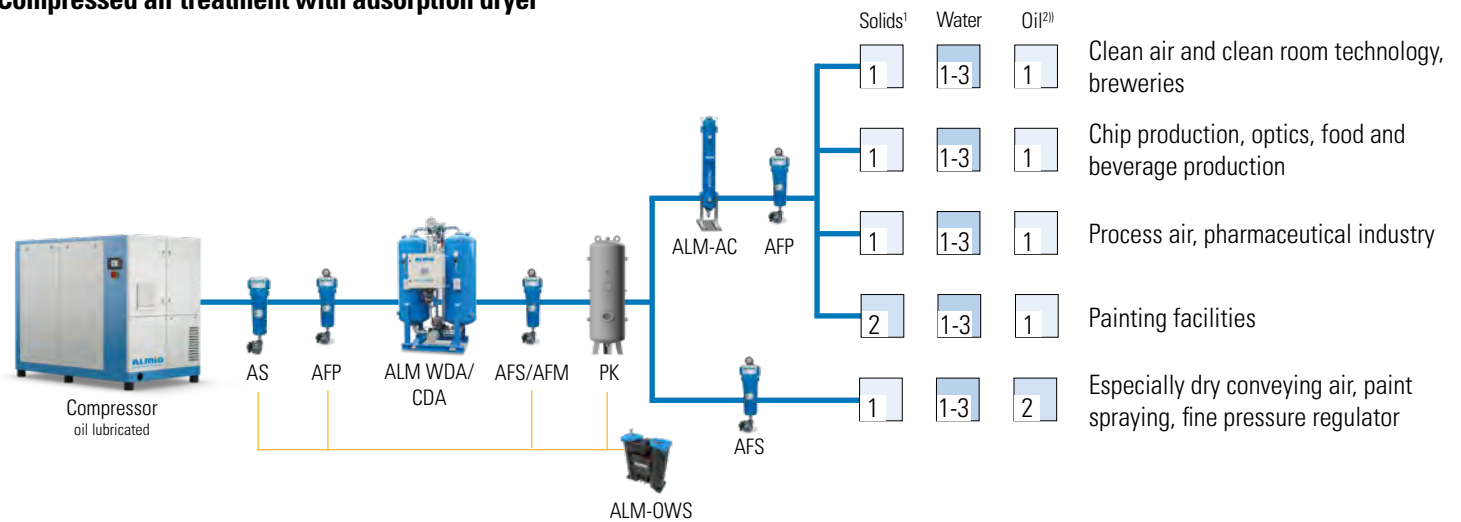

Compressed air treatment with oil-free compressor

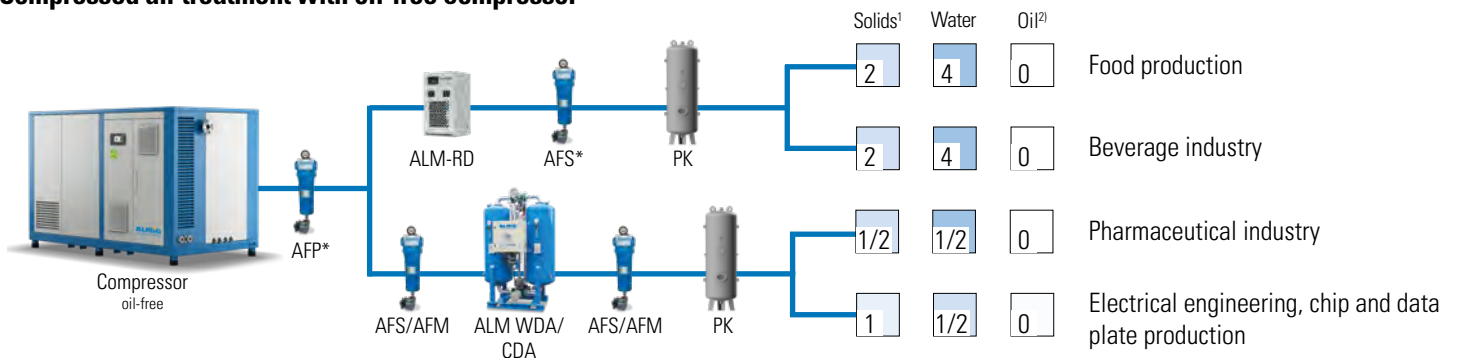

Explanations

AS	Cyclone separator
PK	Compressed air receiver
AFP	Prefilter/coarse filter

AFM	Micro filter
AFS	Submicro filter
AFC	Activated carbon filter

ALM-AC	Activated carbon adsorber
ALM-WDA/ ALM-CDA	Adsorption dryer

ALM-RD	Refrigeration dryer
ALM-OWS	Oil-water separators

Illustrations not to scale.

The overview is intended as a general recommendation for action; the use of various treatment components must be assessed individually on a case-by-case basis. This overview does not claim to be complete.

1) Attainable particle class assuming correctly executed piping and commissioning. 2) Achievable total oil content depending on the intake air and the compressor oils used.

* May be omitted when using the ALM-RD, as these are already integrated in the refrigeration dryer. ** Observe service life.

The compressed air classes refer to standard conditions. When generating oil-free compressed air, the intake air and the ambient conditions also have an influence on the quality. Different service lives for AFC and ALM-AC must be taken into account.

ALMiG COMPRESSED AIR TREATMENT

- + Generation and treatment: Everything from a single source and perfectly matched
- + ALMiG covers the entire range of compressed air treatment products.
- + ALMiG can provide the right kind of compressed air treatment product for every requirement profile.
- + Treatment components can also benefit from our Aircare warranty extension* when purchased with a compressor.

Highly
versatile

FILTERS
AFP, AFM, AFS, AFC

p. 6

Reliable
condensate
drain

CONDENSATE DRAIN
ALM-D

p. 10

Reliable and
robust

**REFRIGERATION
DRYER ALM-RD**

p. 14

Efficient pre-sep-
aration of con-
densate

AS
CYCLONE SEPARATOR

p. 8

For oil-free
condensate

OIL/WATER SEPARATOR
ALM-OWS

p. 12

For oil-free &
flavour-neutral
neutral com-
pressed air

**ACTIVATED CARBON
ADSORBER ALM-AC/CAC**

p. 16



Dry and oil-free compressed air for dew points down to -70°C

**ADSORPTION DRYER
ALM-CCDA C**

p. 20

For pressure dew points down to -70°C

**ADSORPTION DRYER
ALM-CDA**

p. 22



High efficiency with high performance

**ADSORPTION DRYER
ALM-WDA**

p. 24



Compact and efficient

**ADSORPTION DRYER
ALM-CCDA**

p. 18

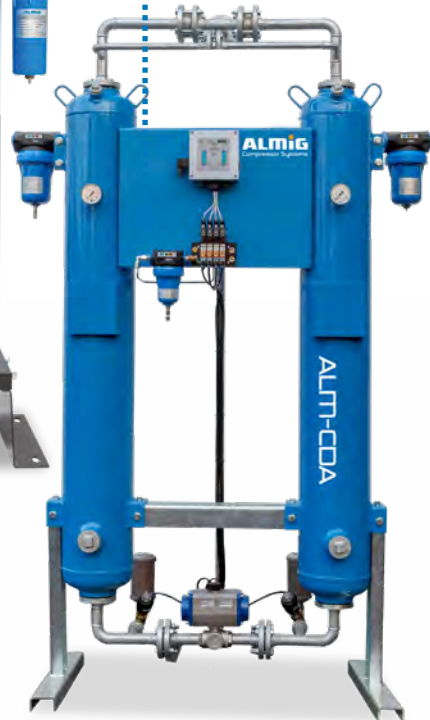

AFP, AFM, AFS, AFC FILTERS

Compressed air filters guarantee clean compressed air to satisfy very stringent requirements.

They can be used in a multitude of applications - wherever compressed air is required clean, dry or free of oil aerosols. It's a huge undertaking, especially when you consider the fact that more than two billion particles and liquid molecules can be present in 1 m³ of compressed air at a compression end pressure of 10 bar.

This is an undertaking to which the ALMiG heavy-duty filters are perfectly suited.

Equipment features:

- Standard version including differential pressure indicator and float drain
- Premium version including
 - differential pressure gauge to display the most cost-effective time to replace the filter element
 - electronically controlled condensate drain to discharge condensate without any loss of compressed air
- Three-part housing with bayonet lock for simple replacement and installation of the filter elements
- Extremely light aluminium housing with threaded connection for volume flows of 30 - 3300 m³/h
- Alternatively, as of volume flows of 2760 - 13750 m³/h, steel housing with flange connection

Application

Industry

Volume flows

30 - 13750 m³/h

Operating temperatures

Minimum: +1 °C

Maximum: +100 °C

The optimum filter for every requirement

Filter type	Type	Particle size µm	Collector efficiency (particle with 1 µm)	Residual oil content ¹	Residual water content ² (in liquid form)
Pre-filter	AFP	5		-	present
Micro filter	AFM	1	99,985 %	0,1	not present ³
Sub microfilter	AFS	0,01	99,99999 %	0,01	not present ³
Active carbon filter	AFC			0,003	not present ³

¹ at inlet concentration of 3 mg/m³
² details relate to a station with no upstream compressed air drying
³ the compressed air no longer contains residual water in a liquid form if the temperature is not reduced downstream of the filter elements (air is 100% saturated)

Filter with threaded connection

Type AFP, AFM, AFS, AFC	Volume flow		Connection	Standard version ¹			Premium version ²		
	Nom. m ³ /h	Max. m ³ /h		Width mm	Height mm	Weight kg	Width mm	Height mm	Weight kg
30	30	37	3/8"	90	233	0.7	90	367	1.0
60	60	75	1/2"	90	233	0.7	90	367	1.0
108	108	135	3/4"	90	293	0.8	90	427	1.1
180	180	225	3/4"	90	293	0.8	90	427	1.1
204	204	255	1"	120	328	1.2	120	452	1.5
300	300	375	1"	120	328	1.3	120	452	1.6
432	432	540	1 1/2"	120	408	1.4	120	532	1.7
570	570	710	1 1/2"	120	408	1.5	120	532	1.8
750	750	935	2"	165	523	3.8	165	647	4.1
990	990	1235	2"	165	523	3.9	165	647	4.2
1140	1140	1425	2 1/2"	165	698	4.9	165	822	5.2
1320	1320	1650	2 1/2"	165	698	5.0	165	822	5.3
1680	1680	2100	3"	200	735	6.8	200	857	7.1
2100	2100	2625	3"	200	888	8.0	200	1012	8.3
2640	2640	3300	3"	200	1008	8.9	200	1132	9.2

All details relate to 1 bar (abs), 20°C, 70% RH; ¹ Aluminium housing with threaded connection including float drain and differential pressure indicator

² Aluminium housing with threaded connection including electronically controlled condensate drain and differential pressure gauge, operating pressure: 16 bar., operating temp.: min. +1 °C, max. +100 °C (60 °C)

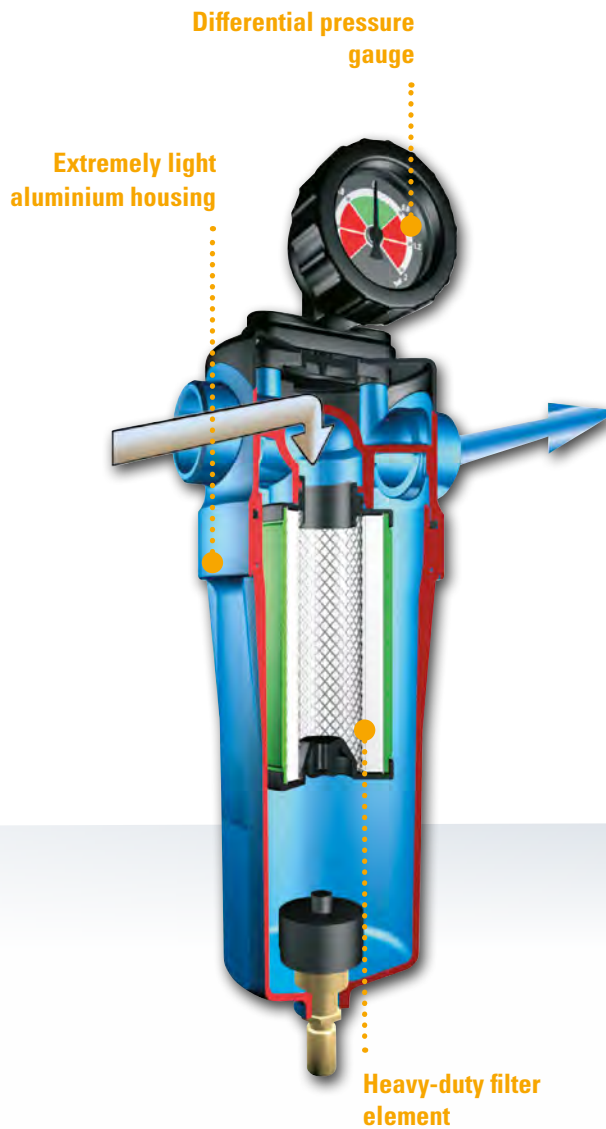

- + Heavy-duty filter for clean and dry compressed air
- + Three-part housing for simple replacement of filter elements
- + Available as standard or premium version



AFP, AFM, AFS, AFC filters

Filter with flange connection

Type AFP, AFM, AFS, AFC	Standard version ¹		Premium version ²			
	Nom.	Max.	Connection	Width	Height	Weight
	m ³ /h	m ³ /h		mm	mm	kg
2760	2760	3450	PN 40	485	1139	125
4200	4200	5250	PN 40	630	1130	196
5700	5700	7125	PN 40	630	1235	210
7500	7500	9375	PN 40	676	1277	264
9300	9300	11625	PN 40	724	1320	314
11000	11000	13750	PN 40	724	1330	320

Operating overpressure p _ü (bar)	1	2	3	4	5	6	7	8	9	10	11	12	13	14	15	16
Correction factor f _{pü}	0.25	0.36	0.5	0.6	0.75	0.9	1	1.1	1.2	1.4	1.5	1.6	1.75	1.9	2	2.1

Conversion factors for other operating overpressures

The volume flows stated relate to a pressure of 7 bar. Volume flows for deviating pressures can be calculated with the correction factors.

Volume flow configuration

The volume flow through the filter element should be between 50% and 100% of the nominal volume flow. Running above or below this, impacts negatively on filter efficiency. The maximum volume flow must not be exceeded.

All details relate to 1 bar (abs), 20 °C, 70% RH.

¹Steel housing with flange connection including float drain and differential pressure indicator

²Steel housing with flange connection including electronically controlled condensate drain and differential pressure gauge, operating pressure: 12 bar, operating temp.: min. +1 °C, max. +66 °C

CYCLONE SEPARATOR AS

The cyclone separators are developed for treating compressed air in industrial areas of use. They are used to remove liquid water from the compressed air, that is drawn in the ambient air due to air humidity and precipitates in the aftercooler. This condensate also contains particles of dirt and aerosols.

It is always a good idea to use a cyclone separator when a refrigeration dryer is installed directly downstream of the compressor so that less condensate precipitates in the refrigeration dryer.

The high centrifugal forces in the cyclone separator cause the water and particles of dirt to be "slung" against the inner wall, from where they slide into a collecting space.

The conical shape of the lower filter housing section means that separated-out aerosols cannot be swept up.

The turbulence-free zone in the lower part of the filter housing prevents condensate already separated in the wet area being swept up again by the air flow.

Due to their optimised design, the three-part housings with twist insert deliver low differential pressures at high flow rates.

As an option, the cyclone separators are also available in a premium version with electronic condensate drain.

Equipment features:

- Standard version including float drain
- Premium version including electronically controlled condensate drain to discharge condensate without any loss of compressed air

Application

Industry

Volume flows

30 - 13800 m³/h

Max. operating pressure

16 bar

Operating temperatures

Minimum: +1 °C
Maximum: +66 °C

Cyclone separator							
	TYPE	Volume flow		Connection	Width	Height	Weight
		Nom. m ³ /h	Max. m ³ /h				
Aluminium housing / threaded connection	30	30	37	3/8"	90	220	0.6
	60	60	75	1/2"	90	220	0.6
	180	180	225	3/4"	90	280	0.7
	300	300	375	1"	120	310	1.1
	570	570	710	1 1/2"	120	390	1.3
	990	990	1235	2"	165	505	3.6
	1320	1320	1650	2 1/2"	165	680	4.7
	2700	2700	3375	3"	200	718	6.2
Steel housing / flange connection	2400	2400	2760	DN 100	420	1030	41
	3000	3000	3450	DN 125	445	1040	55
	6600	6600	7500	DN 150	523	1095	81
	7500	7500	8630	DN 175	606	1180	117
	12000	12000	13800	DN 200	657	1275	157

Cyclone separator - premium version							
	TYPE	Volume flow		Connection	Width	Height	Weight
		Nom. m ³ /h	Max. m ³ /h				
Aluminium housing / threaded connection	30	30	37	3/8"	90	295	0.8
	60	60	75	1/2"	90	295	0.8
	180	180	225	3/4"	90	355	0.9
	300	300	375	1"	120	380	1.3
	570	570	710	1 1/2"	120	460	1.5
	990	990	1235	2"	165	575	3.8
	1320	1320	1650	2 1/2"	165	750	4.9
	2700	2700	3375	3"	200	785	6.4
Steel housing / flange connection	2400	2400	2760	DN 100	420	940	41
	3000	3000	3450	DN 125	445	950	55
	6600	6600	7500	DN 150	523	1005	81
	7500	7500	8630	DN 175	606	1090	117
	12000	12000	13800	DN 200	657	1185	157

All details relate to 1 bar (abs), 20 °C, 70% RH.

Three-part housing
resulting in low differential pressures

Heavy-duty cyclone separator



Turbulence-free zone
Prevents condensate from
being swept up

Float drain

- + Low differential pressures with high flow rates
- + Separated-out aerosols cannot be swept up
- + Available as standard or premium version



AS cyclone separator

ALM-D CONDENSATE DRAIN

You cannot avoid producing condensate when generating compressed air. The condensate contains oil and particles of dirt and may cause corrosion in the receiver, compressed air lines and on the consumer if not reliably drained. The ALM-D condensate drains from ALMiG deliver reliable condensate drainage. Avoiding compressed air losses can result in huge energy savings.

Level-controlled condensate drain ALM-D 10

The ALM-D 10 is a level-controlled condensate drain without compressed air losses for smaller compressed air systems. The ALM-D 10 features a reliable, directly controlled valve with FPM seal and covers pressure ranges of between 0 and 16 bar (up to 230 PSI).

With an inlet height of just 74 mm, the ALM-D 10 is a very compact solution offering unique installation flexibility and reliability.

Given its very compact size and low weight of less than 500 grammes, it is typically used in refrigeration dryers and filters. The maximum compressor capacity of this drain is 10 m³/min (350 CFM).

Equipment features:

- Compact solution with no compressed air losses.
- Very light.
- One model covers all capacities up to a compressor capacity of 10 m³/min.
- The inlet height of just 74 mm makes for simple installation.
- The fact that the valve is located externally means that maintenance is quick and easy.
- Robust, corrosion-resistant aluminium housing.
- Integrated clever valve self-cleaning mode.
- Voltage options: 230/115/24 VAC, 24 VDC.
- DIN 43650-B plug connection.
- IP65 protection class.

Electronically level-controlled condensate drain ALM-D 100

The ALM-D 100 removes all kinds of condensate from compressed air systems of up to 100 m³/min without any air losses.

The compact and robust aluminium housing, the 2/2-way directly controlled valve with a large aperture and the integrated strainer make the ALM-D 100 the most reliable solution available for all compressed air solutions.

Equipment features:

- Compact solution with no compressed air losses.
- Alarm function (NO or NC) integrated as standard.
- Capacitive level control technology saves compressed air, energy and money.
- Robust, corrosion-resistant aluminium housing, EP paintwork.
- Directly controlled valve ensures a reliable condensate drain.
- Integrated stainless steel strainer.
- Voltage options: 230/115/24 VAC, 24 VDC.
- DIN 43650-B plug connection.
- IP65 protection class.

Application

Industry

Max. compressor capacity

ALM-D 10: 10 m³/min

ALM-D 100: 100 m³/min

Min./max. System pressure

0 - 16 bar

Valve type

2/2-way, directly controlled

valve aperture

ALM-D 10: 2 mm

ALM-D 100: 4 mm

Inlet / outlet

1/2" inlet union /

1/4" outlet union

Medium temperature / ambient temperature

1 – 50 °C

- + Incredibly compact
- + Corrosion-resistant aluminium housing
- + Condensate drain free of compressed air losses
- + Unique installation flexibility and reliability



ALM-D 100

OIL-WATER SEPARATOR

ALM-OWS

Condensate is produced when generating compressed air. This condensate is contaminated with oil, which is drawn in from the surrounding air and used in the compressor stage for cooling. Because the contaminated condensate must not be discharged into the sewer system, it has to be separated from the oil.

The ALM-OWS series of oil-water separators reliably removes oil from any condensate produced in compressed air systems.

In order to reliably separate the oil from the water, the condensate passes through several stages of separation and is filtered by several filter elements.

The oil-adsorbing elements combine various kinds of adsorption technology to achieve a residual oil content of less than 10 ppm.

The first oil-adsorbing element has a saturation indicator and provides an optical check, allowing the separator to be monitored visually (even from a distance). The combinations of elements are always analysed and put together on the basis of the latest range of adsorption technologies.

The last stage contains specially selected active carbon for separating the remaining contaminants.

Equipment features:

- Quick and easily replacement of elements.
- Several condensate inlets.
- Test bottle and test drain for taking samples.
- Use of heavy-duty filter elements.
- Simple, quick and clean installation and replacement process.
- Successful separation of mineral oil, synthetic oil and stable condensate emulsions by heavy-duty elements – for maximum reliability.
- Brass hose humps ensure quick and easy installation and maintenance.
- Simple to dispose of in line with environmental requirements.
- All types and designs of condensate drain can be used.
- Compact design and small footprint.

Achievable residual oil content

<10 ppm

Maximum compressor capacity

2 - 60 m³/min

Separation of

mineral oil

synthetic oil

condensate emulsions

Input connection

1/2" (2")

Output terminal

1"

ALM-OWS

TYPE	Compressor capacity	Max. oil absorption of elements	Heavy-duty elements	Active carbon elements	Overflow warning indicator	Indicator showing element's service life	Maintenance drain valve
	m ³ /min	Litres					
02	2	2	1	1	No	No	No
05	5	5	2	1	Yes	Yes	No
10	10	10	2	1	Yes	Yes	Yes
20	20	15	2	1	Yes	Yes	Yes
30	30	25	2	1	Yes	Yes	Yes
60	60	50	2	2	Yes	Yes	Yes

Optical display
Separator can even be
monitored from a distance

**Quick and easy
replacement of elements**



Water drain valves
to simply empty
the individual towers

+ Simple, quick and clean installation and replacement process.

+ Successful separation of mineral oil, synthetic oil and stable condensate emulsions.



ALM-OWS 02



ALM-OWS 05



ALM-OWS 10



ALM-OWS 20



ALM-OWS 30



ALM-OWS 60

REFRIGERATION DRYER

ALM-RD

The use of clean, dry air is extremely important for all types of compressed air-powered applications. Moisture or contaminants in the compressed air can lead to system failures. These complications reduce productivity and can affect the product quality of the end products. So don't compromise and choose the ALM-RD refrigeration dryer series.

Advantages:

- The ALM-RD refrigeration dryers already contain a pre-filter and an after-filter (up to ALM-RD 6220), so that the complete treatment can be covered in the smallest possible space. The required filter change is indicated directly on the display.
- Minimised pressure drop leads to immediate energy savings.
- Fast start-up and response times ensure that the required air quality is achieved quickly.
- Each dryer is specially designed according to its flow with the right

components to ensure the lowest energy consumption.

- High-efficiency R134a refrigerant is standard on all models.
- A state-of-the-art heat exchanger design offers the highest cost savings in the industry.

The refrigerant circuit and insulation of the ALM-RD series

ALMiG uses only the environmentally friendly refrigerant gas R134a in the dryers. R134a has excellent thermodynamic properties and can be operated at very low pressure compared to other refrigerants. This in turn increases the service life of the refrigerant compressor.

ALMiG refrigeration dryers provide a constant pressure dew point of +3°C within their operating range. This is made possible by the use of state-of-the-art refrigeration technology in the manufacture of the dryers.

Refrigeration dryer ALM-RD

Type	Max. Volume flow*	Cooling air requirement	Compressed air connection	Power consumption**	Length	Width	Height	Weight
	m ³ /h	m ³ /h		kW	mm	mm	mm	kg
25	23	180	1/2"	0,34	372	369	707	32
40	38	180	1/2"	0,34	372	369	707	32
56	53	180	1/2"	0,37	372	369	707	32
75	70	180	1/2"	0,38	372	369	707	32
110	100	180	3/4"	0,39	473	454	832	51
165	155	700	3/4"	0,59	473	453	832	53
200	190	700	3/4"	0,68	473	453	832	55
225	210	700	1 1/2"	0,82	556	506	874	78
325	305	700	1 1/2"	1,07	556	506	874	83
400	375	700	1 1/2"	1,19	556	506	874	86
525	495	1100	2"	1,23	678	648	1157	160
660	623	1100	2"	1,32	678	648	1157	165
990	930	1350	2"	2,01	948	728	1370	220
1280	1200	1350	2"	2,59	948	728	1370	230
1480	1388	2800	3"	2,80	948	798	1460	270
1920	1800	2800	3"	3,21	948	798	1460	285
2660	2500	5000	3"	4,10	1163	778	1725	392
2950	2775	5000	3"	4,74	1163	778	1725	410
3540	3300	7000	DN100 Flange	5,74	1577	993	1906	690
4160	3915	7000	DN100 Flange	6,50	1577	993	1906	710
5400	5085	8500	DN100 Flange	8,25	1647	1077	2005	825
6220	5850	8500	DN100 Flange	9,55	1647	993	1959	835
7420	6975	8500	DN150 Flange	11,95	2188	1062	2024	900
8380	7875	12750	DN150 Flange	12,88	2188	1062	2024	925
9580	9000	12750	DN150 Flange	15,40	2247	1200	2043	975
11200	10500	12750	DN200 Flange	15,53	2247	1200	2043	1100
13300	12500	25500	DN200 Flange	20,70	2550	1550	2100	1400

*with 35°C inlet temperature, 7 bar(g), 25°C ambient temperature, pressure dew point +3°C (m³/h); refrigerant: R 134 a; ** average power and current consumption based on 3°C evaporating and 45°C condensing temperature.

Digital control with embedded functions

- Digital dew point monitoring
- Display in energy saving mode
- Display of periodic maintenance intervals
- Status report
- Operating hours counter

- + All-inclusive solution due to integrated pre-filter and after-filter (up to ALM-RD 6220)
- + Pre-filter: particles up to 1µm + residual oil content up to min. 0.5 mg/m³
- + Post-filter: particles up to 0.01 µm + residual oil content up to min. 0.01 mg/m³
- + Low pressure drop
- + Fast start-up and response time
- + Lowest energy consumption
- + State-of-the-art heat exchanger design

Compact design

Integrated pre- and post-filter

Electrical lines are separated from the refrigerant side



Aluminium plate heat exchanger is standard

Easily accessible



ALM-RD 155



ALM-RD 623



ALM-RD 3330

Correction factors for refrigeration dryer ALM-RD

Inlet temperature (°C)	30	35	40	45	50	60	-	-
F1	1,29	1	0,92	0,78	0,65	0,45	-	-
Ambient temperature t _v (°C)	20	25	30	35	40	50	-	-
F2	1,05	1	0,98	0,93	0,84	0,7	-	-
Operating pressure (bar)	4	6	7	8	10	12	14	16
F3	0,80	0,94	1	1,04	1,11	1,16	1,22	1,25

ACTIVATED CARBON ADSORBER ALM AC & ALM-CAC

The ALM-AC & ALM-CAC activated carbon adsorbers supply absolutely oil-free compressed air that is neutral in taste and odour. The special activated carbon ensures the adsorption of oil vapour from the compressed air.

The ALM-AC & ALM-CAC activated carbon adsorbers guarantee:

- Oil-free with a residual oil content $\leq 0.003 \text{ mg/m}^3$ due to high oil vapour absorption. Entry requirements:
- Residual oil content: 0.01 mg/m^3 ; inlet temperature 35°C .
- Service life of the activated carbon of approx. 9,000 operating hours.
- Absolute operational safety.

- Maximum performance, safety and quality.
- A constant degree of efficiency.

Standard version

- Pre- and post-filter ALM-CAC 02-45
- ALM-AC optional (recommendation pre-filter H-degree, post-filter U-degree);
- Oil test indicator optionally available.

Application

Industry

Nominal flow rate inlet

8,40 - 4200 m^3/h

Operating pressure

Max. 16 bar(ü)

Ambient temperature

+2 up to $+45^\circ\text{C}$

ALM-AC & ALM-CAC

TYPE	Nominal throughput at inlet ¹	Length	Width	Height	Weight	Connection
	m^3/h	mm	mm	mm	kg	
ALM-CAC 02	8,40	276	210	420	8	1/4"
ALM-CAC 04	15,60	276	210	670	10	1/4"
ALM-CAC 07	25,20	276	210	920	13	1/4"
ALM-CAC 10	34,80	276	210	1120	14	1/4"
ALM-CAC 15	56,40	406	250	993	26	1/2"
ALM-CAC 20	72	406	250	1243	30	1/2"
ALM-CAC 30	108	565	320	1036	53	1"
ALM-CAC 45	162	565	320	1387	63	1"
ALM-AC 53	190	335	500	1890	115	DN25
ALM-AC 67	240	335	500	2040	125	DN25
ALM-AC 106	380	450	500	1930	191	DN25
ALM-AC 150	540	450	620	2130	218	DN40
ALM-AC 181	650	450	620	2220	230	DN40
ALM-AC 236	850	570	620	2000	276	DN40
ALM-AC 292	1050	570	660	2290	325	DN50
ALM-AC 389	1400	650	800	2200	383	DN80
ALM-AC 472	1700	700	800	2220	455	DN80
ALM-AC 569	2050	750	800	2250	509	DN80
ALM-AC 667	2400	800	800	2250	562	DN80
ALM-AC 778	2800	850	1000	2270	619	DN80
ALM-AC 889	3200	1000	1000	2400	686	DN100
ALM-AC 1028	3700	1000	1000	2420	762	DN100
ALM-AC 1167	4200	1040	1000	2450	830	DN100

¹referred to 1 bar (abs) and 20°C intake condition, 7 bar (g) and 35°C inlet temperature, 16 bar operating pressure

Pre-filter and after-filter
factory-mounted on the dryer

**Compact
Design**

- + Absolute operational safety
- + Maximum performance, safety and quality
- + Constant efficiency



ALM-AC



ALM-CAC

ADSORPTION DRYER

ALM-CCDA

The ALM-CCDA series of compact adsorption dryers cost-effectively provides the highest air quality at the desired extraction point. With reliable technology proven thousands of times in the market, the ALM-CCDA provides the assurance that the production process will operate without interruption - without wear or faults on compressed air tools and with more safety for downstream machines and manufacturing processes.

This series comes complete with built-in pre- and post-filters, filled with desiccant and proven PCB controller with indicator lights to monitor the drying process. The dryers are completely ready for use and only need to be connected to the power supply and the compressed air system. Alternatively, both a potential-free start/stop control and a load-dependent control are available to save energy. The compact adsorption dryers of the ALM-CCDA series meet the requirements of ISO 8573.1 class 1.2.1 as standard. Higher quality classes are available on request.

Features and benefits:

- Use at the extraction point: Air quality where it is needed.
- Easy installation: Connection to power and compressed air supply only required.
- Compact design: Designed for point-of-use, small footprint.
- Easy maintenance: Designed for quick replacement of standard components.
- Universal connection: Can be mounted on the wall or on the floor possible.

Application:

ALM-CCDA dryers provide clean air directly at the point of use.

- Sensitive measuring instruments
- Dental air
- Medical air
- Food packaging
- Prefiltration for gas separation membranes
- Breathing air without CO or CO₂ removal
- Paint spraying

Application

Industry

Pressure dew point
-20°C, -40°C, -70°C

Nominal flow rate inlet
up to 162 m³/h

Operating pressure
4-16 bar

Ambient temperature
+1 °C up to +50 °C

ALM-CCDA						
TYPE	Nominal throughput at inlet ¹⁾	Length	Width	Height	Weight	Connection
	m ³ /h	mm	mm	mm	kg	
02	8,4	366	226	420	14	1/4"
04	15,6	366	226	670	18	1/4"
07	25,2	366	226	920	24	1/4"
10	34,8	366	226	1120	28	1/4"
15	56,4	550	273	993	51	1/2"
20	72	550	273	1243	51	1/2"
30	108	755	338	1036	93	1"
45	162	755	338	1386	114	1"

Correction factor at different operating temperatures and pressures

Pressure bar(i)	Inlet temperature T °C					
	25	30	35	40	45	50
4	0,66	0,64	0,62	0,59	0,55	0,50
5	0,80	0,77	0,75	0,71	0,67	0,63
6	0,94	0,90	0,87	0,84	0,79	0,76
7	1,07	1,03	1,00	0,96	0,92	0,87
8	1,16	1,14	1,11	1,08	1,04	1,00
9	1,23	1,21	1,18	1,14	1,10	1,07
10	1,32	1,30	1,27	1,24	1,20	1,16

¹⁾ based on 1 bar (abs); -40° pressure dew point and 20°C; 0%rh at 7 bar (g) operating pressure and inlet temperature 35°C

- + Cold regenerating
- + Compact and space-saving
- + Easy installation and operation
- + Low maintenance costs

Pre- and after-filter
factory-mounted on the dryer

Extremely compact



High-performance desiccant
Long service life at high input temperatures
for very low pressure dew point.

**Maintenance friendly
Design**

ADSORPTION DRYER

ALM-CCDA C - OIL-FREE

The ALM-CCDA C series of compact adsorption dryers with downstream activated carbon oil vapour adsorber is designed to dry compressed air down to a dew point of -70°C and a residual oil content of 0.003 mg/m³. The compact design allows it to be used directly where dry and technically oil-free compressed air is required.

All dryers are delivered ready for use with pre- and after-filter, desiccant and reliable PCB controller with indicator lights.

Optionally, both a potential-free start/stop control and a load-dependent control are available to save energy.

The compact adsorption dryers meet the requirements of ISO 8573.1 class 1.2.1 as standard, and higher quality classes are available on request.

Features and benefits:

- Adsorption dryer
- Including additional activated carbon stage for oil-free compressed air with residual oil content up to 0.003mg/m³ (at 20°C)
- Including pre-filter and after-filter already mounted on the dryer at the factory.
- Particle separation 0.01 micron pre-filter, 1 micron

post-filter

- Cold regeneration design
- Use at the point of extraction: air quality where it is needed.
- Easy installation: Connection to power and compressed air supply only required.
- Compact design: Designed for point-of-use, small footprint.
- Easy maintenance: Designed for quick replacement of standard components.

Application:

ALM-CCDA C dryers provide clean and oil-free air directly at the point of use.

- Sensitive instruments
- Dental air
- Medical air
- Food packaging
- Prefiltration for gas separation membranes
- Breathing air without CO or CO₂ removal
- Paint spraying

Application

Industry

Pressure dew point

-20°C, -40°C, -70°C

Nominal flow rate inlet

up to 162 m³/h

Operating pressure

4-16 bar

Ambient temperature

+1 °C up to +50 °C

ALM-CCDA C						
TYPE	Nominal throughput at inlet ¹⁾	Length	Width	Height	Weight	Connection
	m ³ /h	mm	mm	mm	kg	
02	8,4	515	226	420	22	1/4"
04	15,6	515	226	670	30	1/4"
07	25,2	515	226	920	38	1/4"
10	34,8	515	226	1120	44	1/4"
15	56,4	773	273	993	77	1/2"
20	72	773	273	1243	92	1/2"
30	108	1050	338	1036	145	1"
45	162	1050	338	1387	178	1"

Correction factor at different operating temperatures and pressures						
Pressure bar(ü)	Inlet temperature T °C					
	25	30	35	40	45	50
4	0,66	0,64	0,62	0,59	0,55	0,50
5	0,80	0,77	0,75	0,71	0,67	0,63
6	0,94	0,90	0,87	0,84	0,79	0,76
7	1,07	1,03	1,00	0,96	0,92	0,87
8	1,16	1,14	1,11	1,08	1,04	1,00
9	1,23	1,21	1,18	1,14	1,10	1,07
10	1,32	1,30	1,27	1,24	1,20	1,16

¹⁾ based on 1 bar (abs); -40° pressure dew point and 20°C; 0%rh at 7 bar (g) operating pressure and inlet temperature 35°C

High-performance desiccant

Long service life at high input temperatures for very low pressure dew point

Extremely compact

- + Residual oil content of 0.003 mg/m³
- + Cold-regenerating
- + Compact and space-saving
- + Simple installation and operation

Pre- and after-filter

factory-mounted on the dryer

Downstream Activated carbon oil vapour adsorber



Maintenance friendly Design

ADSORPTION DRYER

ALM-CDA

Drying compressed air by adsorption is a purely physical process in which water vapour is bound (adsorbed) to a desiccant by deposition. For adsorption, the humid compressed air is passed through the adsorption dryer. As the compressed air flows through the container from bottom to top, the compressed air comes into contact with the hydrophilic desiccant. The desiccant absorbs the moisture and dry compressed air flows out of the container.

ALMiG offers two control systems for the ALM-CDA adsorption dryers:

1. PLC (time-based control)

The HDD adsorption dryer has a time-based PLC control as standard. The standard cycle has five minutes of adsorption, followed by four minutes of desorption (removal of deposited water vapour from the desiccant) and one minute for pressure build-up.

2. LCS (load dependent control)

The LCS control is a load-dependent control with which energy savings can be realised. Instead of the five-minute cycle of the time-based control, the LCS control has a dew point sensor that measures the moisture content at the dryer outlet. The dryer only regenerates when the set dew point is exceeded. This saves purge air and thus energy.

Features and benefits:

- Welded vessels according to ASME or PED standard.
- Other standards and approvals on request
- The use of self-cleaning wedge wire made of stainless steel in the humid area enables an even distribution of the air flow through the dryer with a low differential pressure
- Indicator lights for on/off function, adsorption, desorption and LED indication of dew point (if a dew point sensor is installed)
- Use of a high-performance molecular sieve for use in a wide range of conditions
- Use of standard industrial valves for quick change or maintenance
- Customised versions available on request
- Easy maintenance

Application

Industry

Pressure dew point
-20°C, -40°C, -70°C

Nominal flow rate inlet
up to 4200 m³/h

Operating pressure

4-16 bar

Ambient temperature

+1 °C up to +50 °C

ALM-CDA						
TYPE	Nominal throughput at inlet ¹	Length	Width	Height	Weight	Connection
	m ³ /h	mm	mm	mm	kg	
53	190	1515	610	1953	251	1"
67	240	1515	610	2110	273	1"
106	380	1620	610	1990	417	1"
150	540	1736	637	2211	487	1 1/2"
181	650	1736	637	2312	513	1 1/2"
236	850	1876	637	2084	610	1 1/2"
292	1050	2075	780	2365	729	2"
389	1400	1510	740	2150	959	DN80/3"
472	1700	1620	760	2180	1136	DN80/3"
569	2050	1670	790	2220	1272	DN80/3"
667	2400	1720	860	2270	1404	DN80/3"
778	2800	1770	920	2240	1547	DN80/3"
889	3200	2100	930	2380	1739	DN100/4"
1028	3799	2160	970	2400	1903	DN100/4"
1167	4200	2270	1020	2400	2074	DN100/4"

Correction factor at different operating temperatures and pressures

Pressure bar(g)	Inlet temperature T °C					
	25	30	35	40	45	50
4	0,66	0,64	0,62	0,59	0,55	0,50
5	0,80	0,77	0,75	0,71	0,67	0,63
6	0,94	0,90	0,87	0,84	0,79	0,76
7	1,07	1,03	1,00	0,96	0,92	0,87
8	1,16	1,14	1,11	1,08	1,04	1,00
9	1,23	1,21	1,18	1,14	1,10	1,07
10	1,32	1,30	1,27	1,24	1,20	1,16

¹based on 1 bar (abs); -40°C pressure dew point and 20°C; 0%rh at 7 bar (g) operating pressure and inlet temperature 35°C

- + Cold regenerating
- + Compact and space-saving
- + Easy installation and operation
- + Low maintenance costs



**Alternating
regenerating
Container**

**Maintenance
friendly
Design**

Control

PLC (time-based control) or LCS
(load-dependent control)

ADSORPTION DRYER

ALM-WDA

Two containers connected in parallel are needed for the continuous drying process using adsorption drying. Each vessel is filled with desiccants that act as a drying medium.

For ALMiG heat regenerating adsorption dryers, high performance desiccants are used which have a long lifetime at high inlet temperatures and thus ensure very low pressure dew points.

The advantage of a vacuum system over other heat regenerating systems is the lower evaporation temperature. Under vacuum conditions, water evaporates at a lower temperature than under pressure conditions. This shortens the heating time, which is cost effective in terms of energy savings.

Advantages:

- The welded steel tanks are designed according to PED 2014/68/EU (other standards and approvals are available on request).
- A stainless steel slotted screen in the wet section of the tank is a self-cleaning system that allows for even distribution of airflow with low pressure differential throughout the system

- Touch screen control for continuous monitoring to communicate with customer's control equipment via integration of Profibus and Modbus
- interfaces
- Additional integrated monitoring of inlet and outlet temperatures
- Features load sensing control (LCS) as standard
- Use of standard industrial valves for fast availability and easy maintenance
- Low energy consumption, fast return on investment
- No purge air is required for regeneration /
- "ZERO PURGE"

Application

Industry

Pressure dew point

-40°C at 100%

nominal load

Nominal flow rate inlet

800 - 7120 m³/h

Operating pressure

4 - 10 bar(ü)

Ambient temperature

+1°C up to +40 °C

Dimensioning:

$$V_{nom} = 2000 \text{ m}^3/\text{h}$$

Inlet temperature = 30°C

Operating overpressure = 10 bar

$$V_{korr} = \frac{V_{nom}}{f_p \cdot f_T}$$

$$V_{korr} = \frac{2000 \text{ m}^3/\text{h}}{1,37 \cdot 1} = 1460 \text{ m}^3/\text{h}$$

Calculated dryer size: ALM-WDA 464

ALM-WDA						
TYPE	Nominal throughput at inlet ¹	Length	Width	Height	Weight	Connection
	m ³ /h	mm	mm	mm		G
222	800	1290	1250	2350	750	DN50/2"
333	1200	1550	1400	2510	1106	DN80/3"
464	1670	1610	1480	2550	1493	DN80/3"
583	2100	1670	1630	2570	1792	DN80/3"
750	2700	2050	1620	2970	2335	DN100/4"
917	3300	2060	1670	3000	2755	DN100/4"
1056	3800	2170	1770	3010	3188	DN100/4"
1167	4200	2200	1800	3030	3600	DN100/4"
1361	4900	2500	1800	3180	4060	DN150/6"
1556	5600	2560	1870	3200	4713	DN150/6"
1708	6150	2620	2120	3220	5370	DN150/6"
1978	7120	2690	2200	3250	5895	DN150/6"

Correction factor at different Operating temperatures and pressures				
Pressure bar(ü)	Inlet temperature T °C			
	25	30	35	40
4	0,66	0,64	0,62	0,59
5	0,80	0,7	0,75	0,71
6	0,94	0,90	0,87	0,84
7	1,07	1,03	1,00	0,96
8	1,16	1,14	1,11	1,08
9	1,23	1,21	1,18	1,14
10	1,32	1,30	1,27	1,24

¹ based on 1 bar (abs) and 20°C; at 7 bar (g) operating pressure and inlet temperature 35°C

High-performance desiccant

Long service life at high input temperatures
for very low pressure dew point.

Vacuum system

for lower evaporation temperatures and thus
reduced heating time to achieve energy savings.

- + Proven technology
- + Robust construction
- + Reliable performance
- + Easy maintenance
- + No purge air, "ZERO PURGE"



Load-dependent control

Maximising adsorption time and minimising regeneration time for economical and energy-saving operation.

ALMiG

POWERFUL TECHNOLOGIES FOR EVERY APPLICATION

ALMiG is one of the leading compressed air technology system providers and has decades of experience delivering premium products in the compressed air sector. Companies all around the world trust in our customer focused solutions, our quality, innovation and flexibility.

Constant research and development form the essential foundations for the efficiency of every system manufactured by ALMiG. Only these constant enhancements and improvements enable us to react quickly and flexibly to individual customer wishes. This approach is complemented by our comprehensive understanding of the sector and extensive service offering which enable ALMiG to stand as skilled partners alongside every customer whatever the issue.

Our customers receive from ALMiG sophisticated compressor technologies and extensive service provision. The latest technologies combine excellence with the quietest possible running performance, optimal energy efficiency and particularly careful conservation of resources. You see: it pays to get to know our long-established Swabian company.

[ALMiG: Compressor Systems Made in Germany](#)

Our compressors meet the acceptance conditions according to:

- ISO 1217-3 Annex C-2009
- ASME
- OSHA

and comply with the CE guidelines. Even the strictest acceptance conditions such as DNV-GL, BUREAU VERITAS, LLOYD'S REGISTER OF SHIPPING, ABS and others are a matter of course for us.

The ALMiG company is certified according to: IRIS 02, ISO 9001: 2008, ISO 14001: 2004



Service - Anytime. Worldwide.

High-quality products such as ALMiG's compressed air solutions deserve first-class service. We therefore offer you the complete service program: from comprehensive consulting, to ensuring availability and increasing economic efficiency, to the development of energy saving potentials. Reliability, fast response times and competent advice are our top priorities. We offer a comprehensive network of highly qualified ALMiG service technicians, certified according to SCC** (Safety Certificate Contractors), and specially trained and authorised service partners. In this way we ensure the operational safety of your compressed air station at all times, both at home and abroad.

- Consulting, planning and installation
- Measurements of compressed air consumption and quality
- Maintenance contracts
- Original spare parts
- Further training, including energy-saving and compressed air seminars



The ALMiG AIRCARE package gives you the opportunity to assert claims for rectification of defects even after the statutory warranty period has expired. Keep a full overview of your service costs and avoid unpleasant surprises.

The special feature of ALMiG AirCare is that this extension **not only includes the newly purchased ALMiG compressor(s), but also additional components** such as refrigeration dryers, filters etc. (see AirCare Conditions).

Our products

Efficiency and sustainability are ALMiG's guiding values. With the „Green & Blue“ orientation, we are constantly developing our products with regard to resource-saving and environmentally compatible use. In the „Blue“ area, we are continuously working on increasingly efficient compressors in order to reduce the energy consumption of the plants and achieve an ever better specific performance.

The „Green“ area includes our oil-free compressors and components for compressed air treatment. The less oil is used, and thus gets into the environment together with other dirt particles, the better for our environment. That is why we are continuously developing our oil-free systems further and our treatment components are also undergoing a constant optimisation process.



Oil-injected compressors

- High efficiency and reliability
- All possible drive options
- Low maintenance costs
- Low noise level

Power range: 4 to 315 kW
Volume flow: 0.27 - 62.7 m³/min
Operating pressure up to 13 bar



Speed-controlled compressors

- Highly efficient
- Adjust exactly to the compressed air requirement
- Costly idle times are reduced to a minimum

Power range: 5.5 to 315 kW
Volume flow: 0.27 - 62 m³/min
Operating pressure up to 13 bar



Oil-free compressors

- 100 % oil-free compressed air
- Extremely low energy consumption during operation
- User-friendly microprocessor control
- Minimum maintenance effort
- Air or water cooling

Power range: 15 to 2240 kW
Volume flow: 0.21 - 330 m³/min
Operating pressure up to 10 bar



Compressed air treatment

- Low pressure loss
- Reliable cleaning of the compressed air
- Safety in operation



ALMiG Kompressoren GmbH
Adolf-Ehmann-Str. 2
73257 Köngen
Tel.: +49 (0)7024 9614-0
info@almig.de

www.almig.com



Subject to errors and modifications

Treatment_072022